



MAMMUT

2 STD

DALL' ESPERIENZA DECENNALE SUI CAMPI GARA MONDIALI MOTOGP E SBK ACQUISITA GRAZIE ALLE NOSTRE TERMOCOPERTE, DALLA PASSIONE PER LE CORSE, QUELLA VERA E SPASMODICA, QUELLA CHE INSEGNA A VIVERE IN SINTONIA CON GLI ADDETTI AI LAVORI E COMPRENDERE I LORO METODI E LE LORO REALI NECESSITÀ DI MIGLIORAMENTO, NASCONO MOLTE IDEE CHE OGGI SI MATERIALIZZANO IN PRODOTTI RACING INNOVATIVI, COME I NUOVI CAVALLETTI CAPIT.

Concepiti per agevolare i complessi e precisi metodi di alloggiamento dei cerchioni, nonché gestire l'importantissimo preriscaldamento dei pneumatici:

- in alluminio di qualità (i più leggeri e pratici sul mercato), robusti ed affidabili;
- cablaggio a spina 230V;
- già in dotazione a teams di spessore nel MotoGP e SBK.

FROM OUR 10 YEARS EXPERIENCE ON THE WORLD MOTOGP AND SBK TRACKS MATURED/ACQUIRED THANKS TO OUR TYREWARMERS, FROM OUR PASSION FOR RACING – THE REAL, ARDENT, FIERY ONE, THE ONE THAT MAKES YOU LIVE SIDE BY SIDE WITH PROFESSIONALS AND UNDERSTAND THEIR METHODS AND THEIR REAL IMPROVEMENT NEEDS MANY IDEAS WERE BORN AND TOOK SHAPE IN THE FORM OF OUR INNOVATIVE RACING PRODUCTS RANGE– LIKE THE NEW CAPIT TYREWARMERS RACKS.

Designed To Combine the complex and precise rim preparation methods with the extremely important tyre preheating process:

- built in high quality aluminium (the lightest and the most practical racks on the market), strong and reliable
- 230V cable plug
- already used by important MotoGP and SBK racing teams.

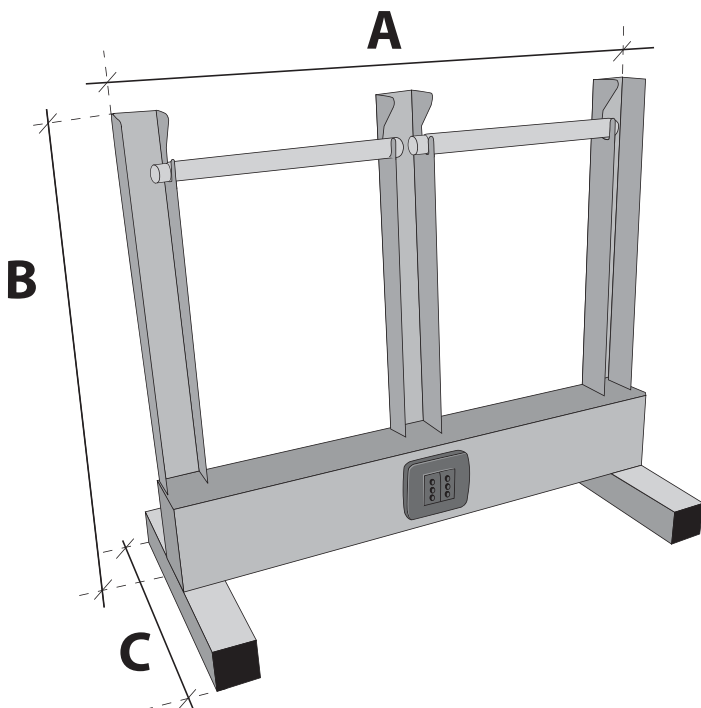

DIMENSIONI DIMENSIONS	DIAMETRO PERNO PIVOT DIAMETER	MATERIALE MATERIAL	ALIMENTAZIONE SUPPLY
A = 67 cm	Ø D = 24 mm	alluminio	110/230 VAC
B = 60 cm	Ø E = 20 mm	alluminium	cavo alimentazione 2 metri con spina blu industriale
C = 35 cm			110/230 VAC power cable length 2 mt with blu industrial plug
PESO / WEIGHT: KG 4,00			

